

QUAD QHD-1 PRO-RA “STING PRO-RA” HYDRAULIC DISC BRAKE SYSTEM

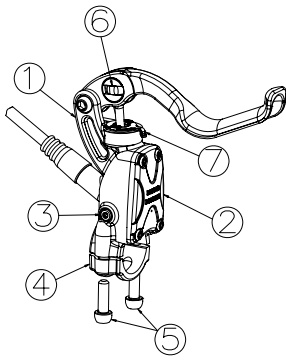

NO	Des.	Q'ty
1.	QHD-1 PRO-RA MC assembly	1
2.	Reservoir cap	1
3.	Torque screw	2
4.	Clamp	1
5.	Clamp bolts	2
6.	Reach adjuster	1
7.	BAT adjuster	1

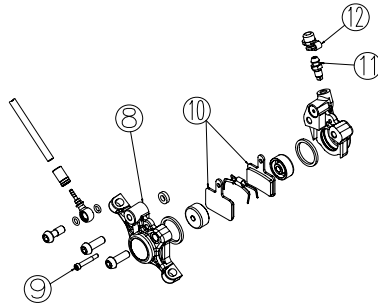

NO	Des.	Q'ty
8.	QHD-1 PRO-RA Caliper assembly	1
9.	Pin for pads	1
10.	Brake pads	2
11.	Bleeding nipple	1
12.	Bleeding nipple cap	1

STANDARD FITTINGS

1. QHD-1 PRO-RA “STING PRO-RA” caliper is compatible with MANITOU forks with a distance between mounting of 74.2mm. It can be converted to International Standard when using our front and/or rear adaptor brackets.
2. Mounting bolts: M6 x 18mm (incl. Washer) x 4pcs.
3. Disc rotor : ϕ 160 for the front and ϕ 140 for the rear; using adaptor brackets, it can be ϕ 180 for the front and ϕ 160 for the rear or ϕ 203 for the front and ϕ 180 for the rear.
4. Rotor screws: 6 pcs.

RELATED MOUNTING SPECIFICATIONS

1. Specifications of front fork and rear dropout

QHD-1 PRO-RA “STING PRO-RA” is compatible to International Standard and POST MOUNT forks, see drawings below :

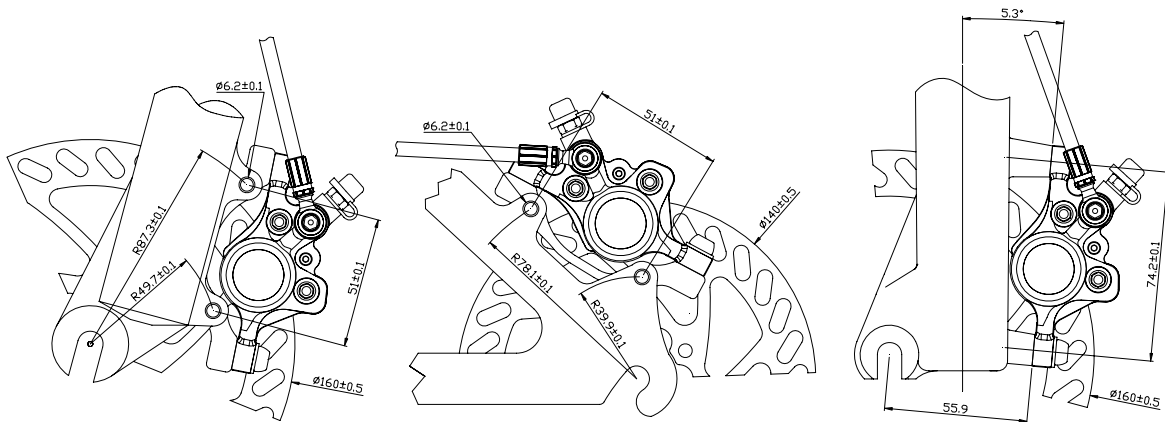

2. Hub

The offset of the hubs for QHD-1 PRO-RA “STING PRO-RA” disc brake system is the same as SHIMANO specifications, see drawings below :

HUB	A	B
front hub	10.5	(15.3min)
rear hub	15.25	(15.3min)

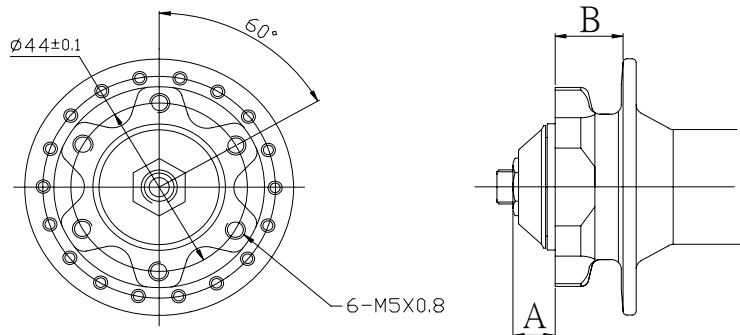

3. Caliper

QHD-1 PRO-RA "STING PRO-RA" caliper is completely sealed, and has been tested to take high pressure. DO NOT loosen any screw/bolt on the caliper (the grub screw can be loosened only when changing brake fluid); otherwise it could cause leaking and consequently no braking.

***Warning :** No brake fluid leaking is allowed. Riding should be stopped at once when there is leaking.

Repairing should be performed by qualified dealers !

4. Rotor

QHD-1 PRO-RA "STING PRO-RA" rotor specifications are ϕ 160x2mm(thickness) for front, ϕ 140x2mm for rear.They can be ϕ 180x2mm for front, ϕ 160x2mm for rear or ϕ 203x2mm for front, ϕ 180x2mm for rear when using adaptor brackets.

***Warning :** 1. **Under normal riding condition**, there will be slight wear on the rotor, wear will be greater after more braking. Therefore it is required to check the wear on rotor regularly. The disc rotor should be changed when it has been deformed or worn excessively.

2. After a long time and or intensive braking, the temperature of the rotor becomes high. Do not touch the rotor.

ASSEMBLY

***Warning :** As the disc pads are self-adjusting, **DO NOT** pull the brake lever before it is fully assembled with the rotor in the caliper slot. The more pulls on brake lever without the rotor in the caliper slot makes the gap between disc pads becomes too narrow. Use the spacer provided with the bike to insert in between the pads and push them back to attain the ideal gap.

I、 Assemble the BMC bracket onto the handle bar.

II、 Use the 6 rotor screws(T25 Torque key, torque 40 ~ 50 kgf-cm) to tighten the disc rotor onto the disc hub.

※Caution :

1. Follow the arrow mark for rotor direction.

2. The 6 rotor screws must be tightened before riding.

3. The 6 rotor screws should be tightened in a diagonal sequence.

4. The 6 rotor screws should be replaced after disassembly for 3-4 times as the Nylok will not function correctly.

III、 Assemble the wheel onto the front fork or rear dropout and tighten the screws or QR.

IV、 Assemble the caliper onto the front fork or rear dropout. :

1. International standard fork :

Tighten the front or rear adaptor bracket onto the front fork or dropout.(Use 2pcs M6x18mm bolts , torque 60±5 kgf-cm).

Mount the caliper to the adaptor bracket with 2pcs M6x18 bolts.(DO NOT TIGHTEN THE BOLTS, so that the caliper can move freely on the bracket)

2. MANITOU fork :

Mount the caliper to the MANITOU fork with 2pcs M6 x 18 bolts. (DO NOT TIGHTEN THE BOLTS, so that the caliper can move freely on bracket)

V、 Pull the brake lever to make the disc pads clamp to the disc rotor (caliper will self adjust alignment),then tighten the 2pcs M6 bolts.

VI、 Spin the wheel to make sure the disc rotor is clear to disc pads. If it is not clear then slack the bolts and redo step V above.

VII、 Turn reach adjuster to adjust the reach of brake lever. (Clockwise, for smaller angle; Anti-clockwise, for larger angle).

VIII、 Turn BAT adjuster to adjust bite point. (Clockwise, for less free travel; Anti-clockwise, for more free travel).

IX、 Test riding :

Braking force on the first 10 ~ 30 pulls is not as powerful.(New disc pads need to be bedded in)

(***Warning :** Do not ride at high speed when doing test riding, keep safe distance.)

MAINTENANCE

I. Changing disc pads :

QHD-1 PRO-RA "STING PRO-RA" hydraulic caliper is designed with self-adjustment disc pad function, No pad adjustment is required before the disc pads are worn out. It is required to stop riding and change new disc pads when the brake lever needs to be pulled with a large travel to stop the bike or there is noise between disc pads and rotor.

***Warning :** Keep disc pads free from oil or grease; otherwise it will cause no braking.

1. Remove the wheel.
2. Insert the spacer into the gap between the disc pads and push the disc pads back to original positions.
See picture1.
3. Use 2mm Allen key to remove the pin holding the disc pads and pull out the disc pads. **See picture2 and 3.**
4. Place new disc pads and spring in the disc pad housing, then place the locating pin through the holes on backing plate of disc pads and tighten the pin (25 kgf-cm). **See picture4 and 5.**
5. Put the wheel back on the fork or dropout and tighten. **See picture6.**
6. Spin the wheel and make sure it is clear between the rotor and disc pads. If it doesn't clear, redo the step VI in Assembly above.

✕Caution :

1. Braking force on the first 10 ~ 30 pulls is not as powerful.(New disc pads need to be bedded in)
Do not ride at high speed when doing test riding, keep a safe distance.
2. It is normal that there might be braking noise in the wet. The noise will disappear after the disc pads become dry.

II、 Changing brake fluid :

QHD-1 PRO-RA "STING PRO-RA" hydraulic disc brake uses Fuchs DOT#4 brake fluid. Other branded DOT#4 brake fluid is compatible.

***Warning :**

1. Never add or mix with other mineral oil or other than DOT#4 fluid as it will cause damage to the seals in the system and cause failure of braking.
2. Brake fluid absorbs moisture after a period of time, which will reduce its boiling temperature. Brake fluid should be changed in 2 years to avoid poor braking.
3. Brake fluid causes irritation to the skin, avoid direct contact the brake fluid.
Water skin once contact to brake fluid.

1. Tools :

- Empty container(for used fluid) · DOT#4 fluid kit
- T 10 Torque key (BMC screw) · 8 mm open-ended wrench (Caliper bleeding nipple)
- QBK-05 twin syringe kit · Plastic insert
- Clean water and a cloth

2. Remove the caliper from front fork or dropout, and keep the torque screw on the BMC in an upper horizontal position.
3. Remove the bleeding nipple from the caliper by using a 8mm open-ended wrench. **See picture ..7**
4. Insert the spacer or disc rotor between the 2 disc pads. **See picture ... 8.**
5. Connect the plastic tube with the appropriate M6 adaptor screw for the caliper to the syringe.
6. Draw up the DOT #4 brake fluid from the bottle and ensuring there are no air pockets.
7. Screw the M6 adaptor into the caliper finger tight. **See picture ..9**
8. Turn BAT adjuster clockwise to the end. **See picture ..10**
9. Remove the torque screw on the upper side of the BMC. **See picture ..11**
10. Connect the plastic tube with the appropriate M5 adaptor screw for the BMC to the syringe.
11. Screw the M5 adaptor into the BMC finger tight. **See picture ..12**
12. Start bleeding:
 - a) Keeping the caliper at the lowest possible position relative to the BMC, inject approximately all the fluid in the caliper syringe until it fills the BMC syringe.
 - b) When the fluid runs clear (no bubble or dirt) in the BMC syringe, remove the BMC syringe and adaptor and replace the torque screw. (10 kgf-cm torque). **See picture ..13**
 - c) Remove the caliper syringe and M6 adaptor and replace the bleeding nipple and tighten to 40-50

kgf-cm torque. **See picture ..14**

13. Wash any excess fluid from the BMC and caliper with clean water. **See picture ..15**
14. Priming: Slide the caliper onto the rotor and screw in the 2pcs M6x 18 bolts but not fully tightened, still allowing the caliper to move freely side to side. Keep pumping until the lever feels firm against the rotor..
15. Pump the BMC lever until the pads clamp the rotor. Whilst maintaining the pressure, screw the 2pcs M6x 18 bolts tightly to the mounting bracket. **See picture ..16**
16. Should the lever on the BMC pull back too far, repeat the bleeding process as above. **See picture ..17**

III、 Shortening the hose :

1. Tools :

- 8mm open-ended wrench
- QBK-02 shortening kit
- Hose cutter or sharp knife
- Clean water and a cloth

※ **Hose must be of correct specification.**

2. Cutting hose :

- a) Re-route the hose to approximately the length required from caliper end and then marked with a pen.
- b) Slide back the rubber hose cone past the cutting mark.
- c) Using the 8mm open-ended wrench to unscrew the compression nut from the BMC.
- d) Pull the hose out of the BMC and **ensuring** the hose remains higher at all times than the caliper.
- e) Slide the compression nut past the marked length.
- f) Trim the hose to the position previously marked, slide on the new compression bush from the shortening kit with the chamfered end to the hose, insert the hose end fitting pushing fully into the hose upto the shoulder, place the rubber O ring on the end of hose end fitting.
- g) Re-insert the hose into the BMC pushing firmly home, slide the compression nut and screw into the BMC. Tighten the compression nut with an 8mm open-ended wrench to between 50 -60 kgf-cm torque.
- h) Slide the rubber hose cone over the compression nut.

Standard hose length of QHD-1 PRO-RA "STING PRO-RA" : for front → 1000mm
for rear → 1550mm

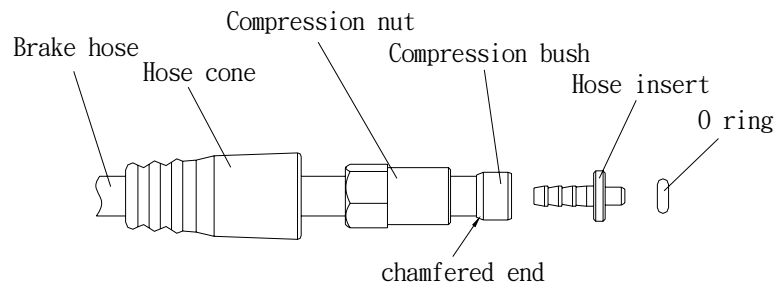

IV. Changing hose :

Please contact a qualified dealer for correct replacement accessories.



Picture 1



Picture 2



Picture 3



Picture 4



Picture 5



Picture 6



Picture 7



Picture 8



Picture 9



Picture 10



Picture 11



Picture 12



Picture 13



Picture 14



Picture 15



Picture 16



Picture 17